

Integrated transformer welding guns

Electrical Drive Available

XL «X» shape



Possible arm configurations

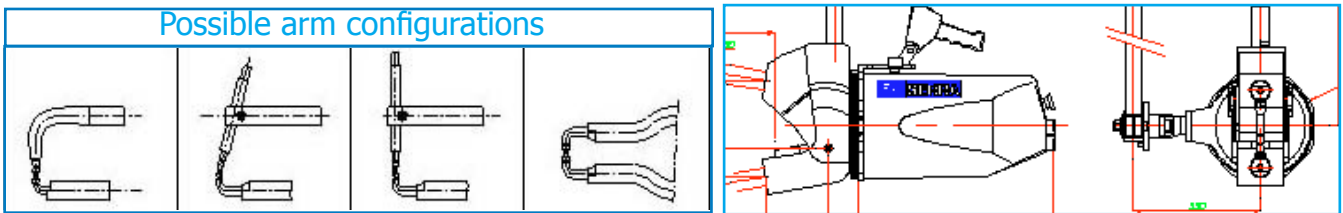

	Pneumatic drive	Electric drive
Power at 50% DC	AC: 45 - 65 kVA • MF: 100 kVA	
Secondary voltage	45 kVA: 7,1 V • 65 kVA : 8,5 V	
Available throat depths	300 mm • 400 mm • 500 mm • 600 mm	
∅ Welding cylinder	100 mm	-
Available welding forces	413 daN • 337 daN • 284 daN • 245 daN	
Cylinder stroke	25+30 mm	
Maximum air pressure	6 bar	-
Cooling water consumption	10 l/m	
Clearance between arms	250 mm (Option 10°)	
Maximum force	460 daN	500 daN
Weigh 45 kVA gun (without arms)	62 kg	66 kg
Weigh 65 kVA gun (without arms)	65 kg	69 kg



Integrated transformer welding guns

Type **C**
AC-MF

Electrical Drive
Available

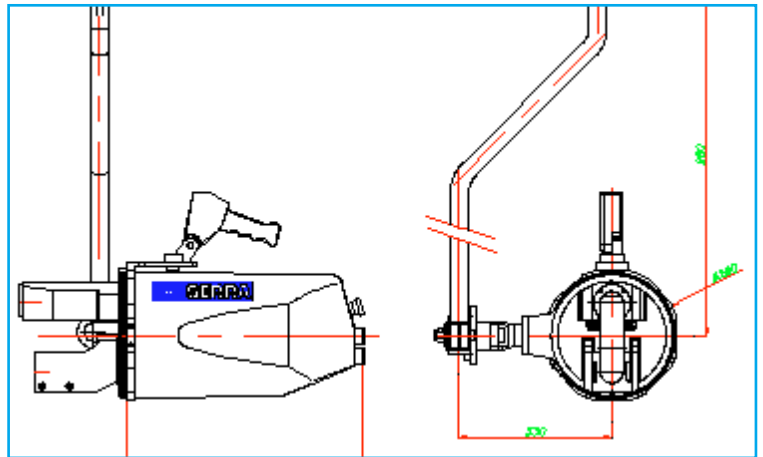

	Pneumatic drive	Electric drive
Power at 50% DC	AC: 45 - 65 kVA • MF: 100 kVA	
Secondary voltage	45 kVA: 7,1 V • 65 kVA : 8,5 V • MF : 9,0 V	
∅ welding cylinder	100 mm	-
Cylinder stroke	100+45 mm	130 mm
Maximum air pressure	6 bar	-
Cooling water consumption	10 l/m	
Clearance between arms	150 mm	
Maximum force	460 daN	750 daN
Weigh 45 kVA gun (ex arms)	57 Kg	60 Kg
Weigh 65 kVA gun (ex arms)	60 Kg	63 Kg

Possible arm configurations

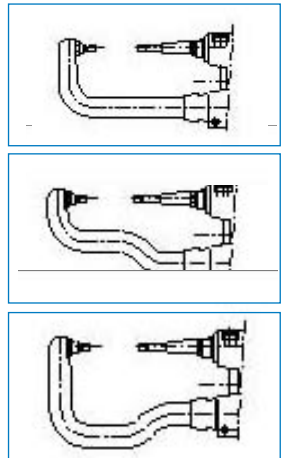

SERRA SOLDADURA, S.A.
Zona Franca, Sector C, Calle D, nº 29.
E-08040 BARCELONA
Tel. +34.93.26.17.100 Fax +34.93.26.17.110
www.serrasold.com

QUALITY MANAGEMENT
Certificate
Voluntary participation in regular monitoring according to ISO 9001:2000



ENVIRONMENTAL MANAGEMENT
Certificate
Voluntary participation in regular monitoring according to ISO 14001

